



**Sorensen**  
XT Series  
Programmable DC  
Power Supply  
Operation Manual



## **About AMETEK**

AMETEK Programmable Power, Inc., a Division of AMETEK, Inc., is a global leader in the design and manufacture of precision, programmable power supplies for R&D, test and measurement, process control, power bus simulation and power conditioning applications across diverse industrial segments. From bench top supplies to rack-mounted industrial power subsystems, AMETEK Programmable Power is the proud manufacturer of Elgar, Sorensen, California Instruments and Power Ten brand power supplies.

AMETEK, Inc. is a leading global manufacturer of electronic instruments and electromechanical devices with annualized sales of \$2.5 billion. The Company has over 11,000 colleagues working at more than 80 manufacturing facilities and more than 80 sales and service centers in the United States and around the world.

## **Trademarks**

AMETEK is a registered trademark of AMETEK, Inc. Sorensen is a trademark owned by AMETEK, Inc. Other trademarks, registered trademarks, and product names are the property of their respective owners and are used herein for identification purposes only.

## **Notice of Copyright**

*XT Series Programmable DC Power Supply Operation Manual* © 2007 AMETEK Programmable Power, Inc. All rights reserved.

## **Exclusion for Documentation**

UNLESS SPECIFICALLY AGREED TO IN WRITING, AMETEK PROGRAMMABLE POWER, INC. ("AMETEK"):

- (a) MAKES NO WARRANTY AS TO THE ACCURACY, SUFFICIENCY OR SUITABILITY OF ANY TECHNICAL OR OTHER INFORMATION PROVIDED IN ITS MANUALS OR OTHER DOCUMENTATION.
- (b) ASSUMES NO RESPONSIBILITY OR LIABILITY FOR LOSSES, DAMAGES, COSTS OR EXPENSES, WHETHER SPECIAL, DIRECT, INDIRECT, CONSEQUENTIAL OR INCIDENTAL, WHICH MIGHT ARISE OUT OF THE USE OF SUCH INFORMATION. THE USE OF ANY SUCH INFORMATION WILL BE ENTIRELY AT THE USER'S RISK, AND
- (c) REMINDS YOU THAT IF THIS MANUAL IS IN ANY LANGUAGE OTHER THAN ENGLISH, ALTHOUGH STEPS HAVE BEEN TAKEN TO MAINTAIN THE ACCURACY OF THE TRANSLATION, THE ACCURACY CANNOT BE GUARANTEED. APPROVED AMETEK CONTENT IS CONTAINED WITH THE ENGLISH LANGUAGE VERSION, WHICH IS POSTED AT [WWW.PROGRAMMABLEPOWER.COM](http://WWW.PROGRAMMABLEPOWER.COM).

## **Date and Revision**

February 2009 Revision C

## **Part Number**

TM-XTOP-01XN

## **Contact Information**

Telephone: 800 733 5427 (toll free in North America)  
858 450 0085 (direct)  
Fax: 858 458 0267  
Email: [sales@programmablepower.com](mailto:sales@programmablepower.com)  
[service@programmablepower.com](mailto:service@programmablepower.com)  
Web: [www.programmablepower.com](http://www.programmablepower.com)

This page intentionally left blank.

# Important Safety Instructions

Before applying power to the system, verify that your product is configured properly for your particular application.

	<b>Hazardous voltages may be present when covers are removed. Qualified personnel must use extreme caution when servicing this equipment. Circuit boards, test points, and output voltages also may be floating above (below) chassis ground.</b>
	<b>The equipment used contains ESD sensitive parts. When installing equipment, follow ESD Safety Procedures. Electrostatic discharges might cause damage to the equipment.</b>

Only *qualified personnel* who deal with attendant hazards in power supplies, are allowed to perform installation and servicing.

Ensure that the AC power line ground is connected properly to the Power Rack input connector or chassis. Similarly, other power ground lines including those to application and maintenance equipment *must* be grounded properly for both personnel and equipment safety.

Always ensure that facility AC input power is de-energized prior to connecting or disconnecting any cable.

In normal operation, the operator does not have access to hazardous voltages within the chassis. However, depending on the user's application configuration, **HIGH VOLTAGES HAZARDOUS TO HUMAN SAFETY** may be normally generated on the output terminals. The customer/user must ensure that the output power lines are labeled properly as to the safety hazards and that any inadvertent contact with hazardous voltages is eliminated.

Guard against risks of electrical shock during open cover checks by not touching any portion of the electrical circuits. Even when power is off, capacitors may retain an electrical charge. Use safety glasses during open cover checks to avoid personal injury by any sudden component failure.

Neither AMETEK Programmable Power Inc., San Diego, California, USA, nor any of the subsidiary sales organizations can accept any responsibility for personnel, material or inconsequential injury, loss or damage that results from improper use of the equipment and accessories.

## SAFETY SYMBOLS

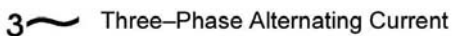
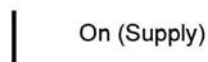
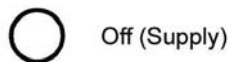
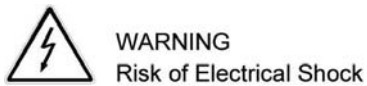

This page intentionally left blank.

## Product Family: XT Series Programmable DC Power Supply

Warranty Period: Five Years

### WARRANTY TERMS

AMETEK Programmable Power, Inc. ("AMETEK"), provides this written warranty covering the Product stated above, and if the Buyer discovers and notifies AMETEK in writing of any defect in material or workmanship within the applicable warranty period stated above, then AMETEK may, at its option: repair or replace the Product; or issue a credit note for the defective Product; or provide the Buyer with replacement parts for the Product.

The Buyer will, at its expense, return the defective Product or parts thereof to AMETEK in accordance with the return procedure specified below. AMETEK will, at its expense, deliver the repaired or replaced Product or parts to the Buyer. Any warranty of AMETEK will not apply if the Buyer is in default under the Purchase Order Agreement or where the Product or any part thereof:

- is damaged by misuse, accident, negligence or failure to maintain the same as specified or required by AMETEK;
- is damaged by modifications, alterations or attachments thereto which are not authorized by AMETEK;
- is installed or operated contrary to the instructions of AMETEK;
- is opened, modified or disassembled in any way without AMETEK's consent; or
- is used in combination with items, articles or materials not authorized by AMETEK.

The Buyer may not assert any claim that the Products are not in conformity with any warranty until the Buyer has made all payments to AMETEK provided for in the Purchase Order Agreement.

### PRODUCT RETURN PROCEDURE

1. Request a Return Material Authorization (RMA) number from the repair facility (**must be done in the country in which it was purchased**):
  - **In the USA**, contact the AMETEK Repair Department prior to the return of the product to AMETEK for repair:  
Telephone: 800-733-5427, ext. 2295 or ext. 2463 (toll free North America)  
858-450-0085, ext. 2295 or ext. 2463 (direct)
  - **Outside the United States**, contact the nearest Authorized Service Center (ASC). A full listing can be found either through your local distributor or our website, [www.programmablepower.com](http://www.programmablepower.com), by clicking Support and going to the Service Centers tab.
2. When requesting an RMA, have the following information ready:
  - Model number
  - Serial number
  - Description of the problem

**NOTE:** Unauthorized returns will not be accepted and will be returned at the shipper's expense.

**NOTE:** A returned product found upon inspection by AMETEK, to be in specification is subject to an evaluation fee and applicable freight charges.

This page intentionally left blank.



# About This Manual

This Operating Manual contains operation instructions for the XT Series of high performance, switching, laboratory power supplies, available in several voltage models at 60 watts. It provides information on features and specifications, installation procedures, and basic functions testing, as well as operating procedures for using both standard and multiple supply functions.

## Who Should Use This Manual

This manual is designed for the user who is familiar with basic electrical laws, especially as they apply to the operation of power supplies. This implies a recognition of Constant Voltage and Constant Current operating modes and the control of input and output power, as well as the observance of safe techniques while calibrating, making supply connections and/or any changes in configuration.

## Main Sections

**Section 1 Features and Specifications** Describes the power supply, lists its features, and provides tables of specifications.

**Section 2 Installation** Reviews safety and inspection procedures, and provides procedures for basic setup. Also includes directions for the testing of basic functions.

**Section 3 Load Connection and Sensing** Provides procedures for connecting the load, grounding, and remote sensing.

**Section 4 Operation** Describes standard operation (Constant Voltage and Constant Current), and series, parallel, and split supply operation.



# Contents

<b>Section 1.</b>	Introduction . . . . .	11
<b>Features and Specifications</b>	Features . . . . .	12
	Options and Accessories . . . . .	12
	Front Panel Controls . . . . .	13
	Rear Panel Connectors and Outputs . . . . .	14
	Electrical Specifications . . . . .	15
	Additional Electrical Specifications . . . . .	17
	Input Conditions . . . . .	17
	Electrical Characteristics . . . . .	17
	Environmental Specifications . . . . .	18
	Mechanical Specifications . . . . .	18
	Chassis Dimensions and Weight . . . . .	19
	Single Output Unit . . . . .	19
	Dual Output Unit . . . . .	19
	Triple Output Unit . . . . .	19
	Quad Output Unit . . . . .	19
<b>Section 2.</b>	Introduction . . . . .	21
<b>Installation</b>	Basic Setup Procedure . . . . .	21
	Initial Inspection . . . . .	21
	Periodic Cleaning . . . . .	21
	Returning Power Supplies to the Manufacturer . . . . .	22
	Return Material Authorization Policy . . . . .	22
	Packaging for Shipping or Storage . . . . .	23
	Rack Mounting . . . . .	24
	Location and Ventilation . . . . .	24
	AC Input Power Connection . . . . .	24
	AC Input Cord . . . . .	25
	Functional Tests . . . . .	25
	Power-on Check . . . . .	25
	Voltage Mode Operation Check . . . . .	26
	Current Mode Operation Check . . . . .	26
<b>Section 3.</b>	Introduction . . . . .	27
<b>Load Connection and Sensing</b>	Load Connection . . . . .	27
	Load Wiring . . . . .	28
	Making Load Connections . . . . .	29

	Connecting Multiple Loads . . . . .	30
	Grounding . . . . .	30
	Local Sensing . . . . .	31
	Remote Sensing . . . . .	32
<b>Section 4.</b>	Introduction . . . . .	33
<b>Operation</b>	Operating Modes . . . . .	33
	Constant Voltage Mode Operation . . . . .	34
	Constant Current Mode Operation . . . . .	34
	Automatic Mode Crossover . . . . .	35
	Constant Power Loads . . . . .	35
	Using Multiple Supplies . . . . .	35
	Connecting Multiple Supplies in Series (Voltage Mode Only) . . . . .	35
	Connecting Multiple Supplies in Parallel . . . . .	36
	Split Supply Operation. . . . .	37

# Section 1. Features and Specifications

## Introduction

The XT Series of linear, regulated DC power supplies provides reliable, high performance solutions for a broad range of laboratory, development and system applications. The series consists of seven basic models that may be purchased as single units or combined as dual, triple, or quadruple configurations containing any combination of models. (See the chart below for a list of available models.)

Low output noise and ripple, excellent line and load regulation, and a wide variety of options, including analog, RS232 standard, or IEEE-488 controlled programming, make the XT Series the first choice in flexible DC power system design.

**Table 1.1** 60 Watt Series Models

<b>Model</b>	<b>Output Voltage</b>	<b>Output Current</b>
7-6	0-7 V	0-6 A
15-4	0-15 V	0-4 A
20-3	0-20 V	0-3 A
30-2	0-30 V	0-2 A
60-1	0-60 V	0-1 A
120-0.5	0-120 V	0-0.5 A
250-0.25	0-250 V	0-0.25 A

## Features and Specifications

### Features

## Features

- The power supply delivers simultaneous digital displays for both voltage and current, and bar graph displays for monitoring transient changes, which gives the user the benefit of continuous, up-to-date information.
- Ten-turn voltage control permits high resolution setting of the output voltage.
- Current limit is fully adjustable from zero to the rated output with a single turn control.
- The automatic crossover system allows the power supply to automatically switch operating modes into current or voltage mode.
- Impedance-switched remote sensing lets operators display the voltage at the load with no switch ambiguity.
- Multiple units can be connected in parallel or series to produce greater diversity.
- Short-circuit-proof power outlets give greater operating safety.
- These power supplies (available in single, dual, triple and quad outputs) can be combined with one or more 300 watt series power supplies to create mixed units that are ideal for high precision applications.

## Options and Accessories

- Internal Analog Programming (APG) interface for analog signal control of voltage and current, overvoltage protection (OVP), master/slave output tracking, and remote ON/OFF.
- Internal RS-232 interface for serial instrument programming using RS-232 protocol.
- Internal GPIB interface for complete remote digital programming. IEEE-488 standard.
- Optional 200-250 Vac input (Options AC220, AC230 and AC240). Standard is 115 Vac. Optional AC input cords for use in different countries.
- Ten-turn current potentiometer (Option M11). Rack mount kit (Option RM).
- Locking voltage and/or current adjust knobs (Option M13A)
- Optional 115-230 Vac switching unit (Option M43)

### Front Panel Controls

See [Figure 1.1](#) to review the controls, LEDs, and meters located on the unit's front panel.

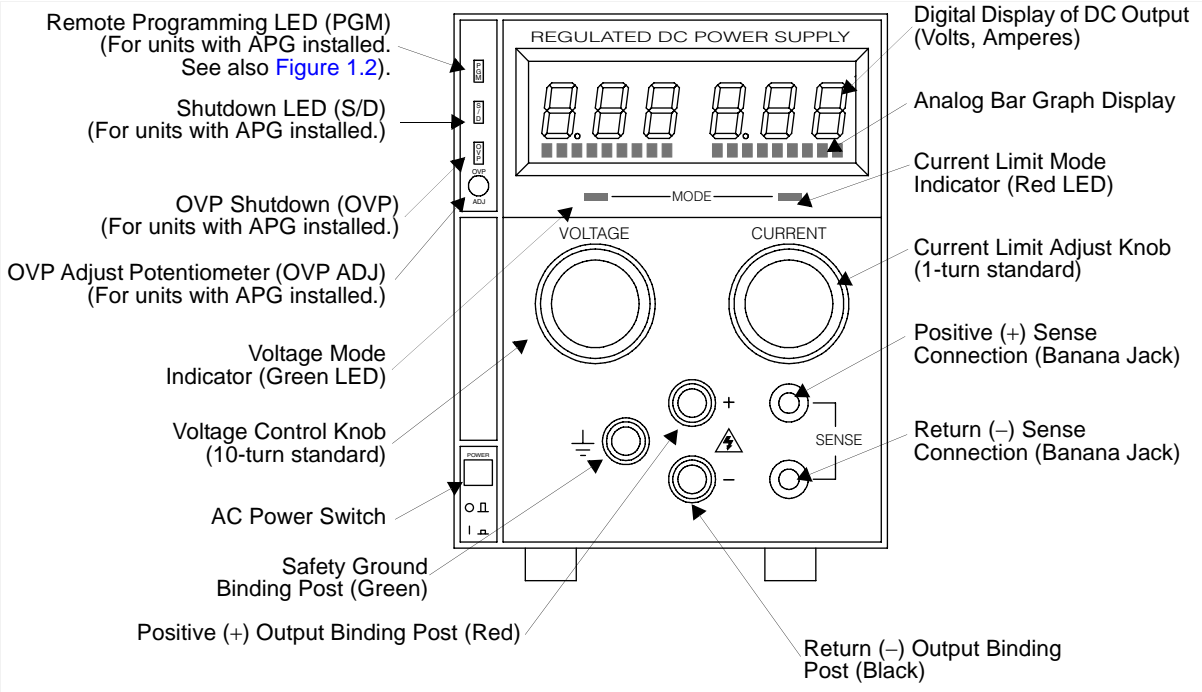
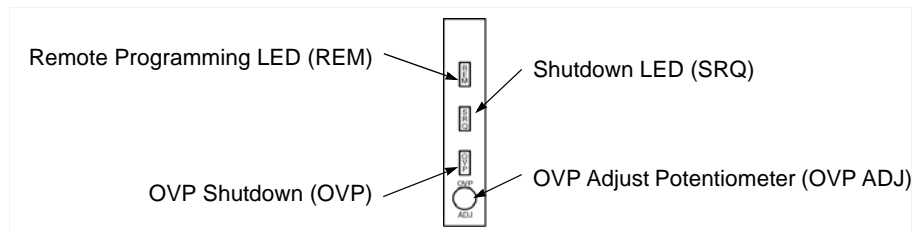

Figure 1.1 Front Panel Controls

## Features and Specifications

### Rear Panel Connectors and Outputs



**Figure 1.2** Remote Programming Interface Indicators (For units with a digital programming interface installed.)

### Rear Panel Connectors and Outputs

See [Figure 1.3](#) for the connectors and outputs available at the rear panel.

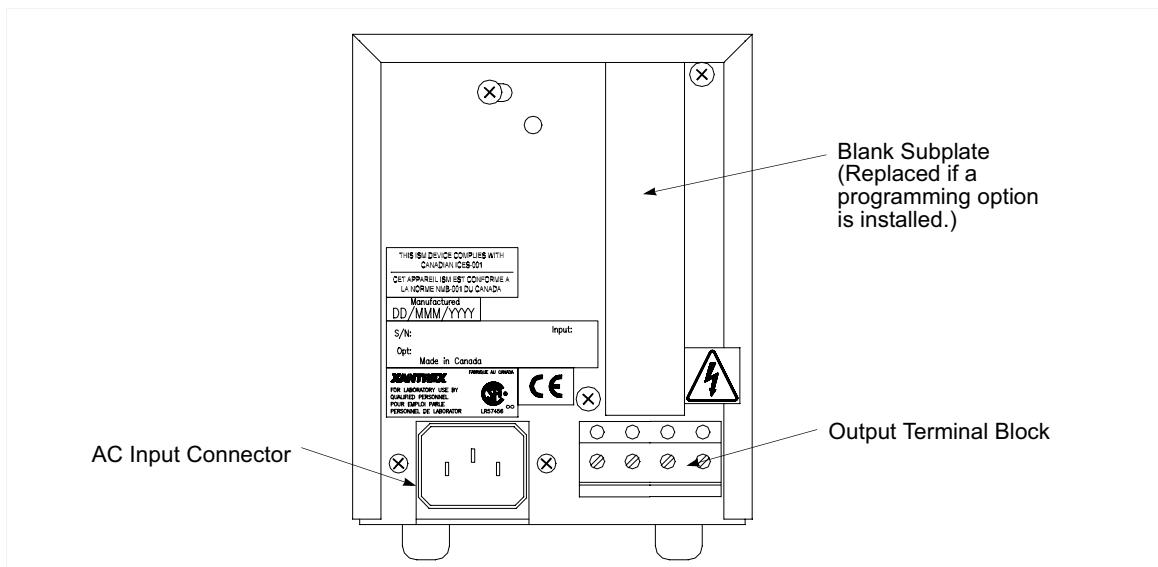

**Figure 1.3** Rear Panel.



## Electrical Specifications

Specifications are warranted over a temperature range of 0 to 30 °C with default local sensing. Above 30 °C, derate output linearly to zero at 70 °C. Specifications are subject to change without notice.

**Table 1.2** Electrical Specifications for 7.5 V to 30 V Models

<b>Models</b>	<b>7-6</b>	<b>15-4</b>	<b>20-3</b>	<b>30-2</b>
<b>Output Ratings:</b>				
Output Voltage	0-7 V	0-15 V	0-20 V	0-30 V
Output Current	0-6 A	0-4 A	0-3 A	0-2 A
Output Power	42 W	60 W	60 W	60 W
<b>Line Regulation: <sup>1</sup></b>				
Voltage (0.01% of Vmax + 2 mV)	2.7 mV	3.5 mV	4 mV	5 mV
Current (0.01% of Imax + 250 uA)	0.85 mA	0.65 mA	0.55 mA	0.45 mA
<b>Load Regulation: <sup>2</sup></b>				
Voltage (0.01% of Vmax + 2 mV)	2.7 mV	3.5 mV	4 mV	5 mV
Current (0.01% of Imax + 250 uA)	0.85 mA	0.65 mA	0.55 mA	0.45 mA
<b>Meter Accuracy:</b>				
Voltage (1% of Vmax + 1 count)	0.08 V	0.25 V	0.3 V	0.4 V
Current (1% of Imax + 1 count)	0.07 A	0.05 A	0.04 A	0.03 A
<b>Stability: <sup>3</sup></b>				
Voltage (0.02% of Vmax)	1.4 mV	3 mV	4 mV	6 mV
Current (0.03% of Imax)	1.8 mA	1.2 mA	0.9 mA	0.6 mA
<b>Temperature Coefficient <sup>4</sup></b>				
Voltage (0.015% of Vmax/°C)	1.05 mV	2.25 mV	3 mV	4.5 mV
Current (0.02% of Imax/°C)	1.2 mA	0.8 mA	0.6 mA	0.4 mA
<b>Front Panel Voltage:</b>				
Control Resolution (0.02% of V max)	1.4mV	3mV	4mV	6mV

1. For input voltage variation over the AC input voltage range, with constant rated load.
2. For 0 to 100% load variation, with constant nominal line voltage, over 15-minute time duration following load step.
3. Maximum drift over 8 hours with constant line, load, and temperature, after 30-minute warm-up at current setpoint.
4. Change in output per °C change in ambient temperature, with constant line and load, and after 30-minute warm-up at current setpoint.

## Features and Specifications

### Electrical Specifications

**Table 1.3** Electrical Specifications for 60 V to 250 V Models

Models	60-1	120-0.5	250-0.25
Output Ratings:			
Output Voltage	0-60 V	0-120 V	0-250 V
Output Current	0-1 A	0-0.5 A	0-0.25 A
Output Power	60 W	60 W	60 W
Line Regulation: <sup>1</sup>			
Voltage (0.01% of Vmax + 2 mV)	8 mV	14 mV	27 mV
Current (0.01% of Imax + 250 uA)	0.35 mA	0.3 mA	0.275 mA
Load Regulation: <sup>2</sup>			
Voltage (0.01% of Vmax + 2 mV)	8 mV	14 mV	27 mV
Current (0.01% of Imax + 250 uA)	0.35 mA	0.3 mA	0.275 mA
Meter Accuracy:			
Voltage (1% of Vmax + 1 count)	0.7 V	2.2 V	3.5 V
Current (1% of Imax + 1 count)	0.02 A	0.006 A	0.003 A
Stability: <sup>3</sup>			
Voltage (0.02% of Vmax)	12 mV	24 mV	50 mV
Current (0.03% of Imax)	0.3 mA	0.15 mA	0.075 mA
Temperature Coefficient <sup>4</sup>			
Voltage (0.015% of Vmax/°C)	9 mV	18 mV	37.5 mV
Current (0.02% of Imax/°C)	0.2 mA	0.1 mA	0.05 mA
Front Panel Voltage:			
Control Resolution (0.02% of V max)	12mV	24mV	50mV

1. For input voltage variation over the AC input voltage range, with constant rated load.
2. For 0 to 100% load variation, with constant nominal line voltage, over 15-minute time duration following load step.
3. Maximum drift over 8 hours with constant line, load, and temperature, after 30-minute warm-up at current setpoint.
4. Change in output per °C change in ambient temperature, with constant line and load, and after 30-minute warm-up at current setpoint.

## Additional Electrical Specifications

Voltage Mode Transient Response Time	<100 $\mu$ s recovery to 0.05% band, for $\pm$ 50% load change in the range of 25% to 100% of the rated load.
Time delay from power on until output stable	1.5 s maximum
Output Noise and Ripple <sup>1</sup>	<1 mVrms (voltage mode) <2 mArms (current mode)
Output Noise and Ripple <sup>1</sup> (250 V unit only)	<5 mVrms (voltage mode) <1 mArms (current mode)

1. RMS value measured at bandwidth of 20Hz to 300kHz, at the rear panel terminals; points of measurement are the positive (+) and return (-) output terminal screws of the output terminal block.

## Input Conditions

Standard AC Input Voltage	115 Vac $\pm$ 10%, 57-63 Hz
Option M1 (Factory installed)	110 Vac $\pm$ 10%, 47-63 Hz
Option AC220	220 Vac $\pm$ 10%, 47-63 Hz
Option AC230	230 Vac $\pm$ 10%, 47-63 Hz
Option AC240	240 Vac $\pm$ 10%, 47-63 Hz
AC Input Current at 115 Vac, 60 Hz	Single unit: 1.2 A Dual unit: 2.4 A Triple unit: 3.6 A Quad unit: 4.8 A

## Electrical Characteristics

Output Hold-up Time	approx. 10 ms at nominal line (full load)
Maximum Voltage Differential from output to safety ground	$\pm$ 400 Vdc
Insulation Resistance	Input to chassis: >120 M $\Omega$ Output to chassis: >120 M $\Omega$
Isolation Voltage (Output not to exceed $\pm$ 400 Vdc from chassis potential.)	Input to output: 1350 Vac

## Features and Specifications

### Environmental Specifications

Maximum Remote Sense Line Drop Compensation. (Line drop must be deducted from the supply's maximum output voltage.)	0.5 V/line
---	------------

## Environmental Specifications

Operating Ambient Temperature	0 to 30 °C with default local sensing. Above 30 °C, derate output linearly to 0 at 70 °C.
Storage Temperature Range	-55° to 85 °C
Humidity Range	Up to 80% RH non-condensing
Operating Altitude	Up to 6,500 feet (2000 m)
Storage Altitude	Up to 50,000 feet (15 000 m)

## Mechanical Specifications

Front Panel Voltage and Current Control	10-turn voltage and 1-turn current potentiometers (10-turn current control optional)
Front Panel Voltage Control Resolution	0.02% of maximum voltage
Front Panel AC Input Power Switch	Push ON/push OFF switch
Front Panel Voltage and Current Meters	Independent 3-digit green numeric LED display and analog bar graph displays for current and voltage. For meter accuracy, see <a href="#">Table 1.2</a> .
AC Input Connector Type	IEC 320 Connector, appropriate power cord for destination country.
Front Panel Output Connector	Three binding posts: positive (+), negative (-), and ground.
Rear Panel Output and Sense Connector	Four terminal block.
Chassis Ground	Front panel binding post and power cord safety ground.
Cooling	Convection cooled. Air enters the unit from the bottom and lower sides and exits from the upper sides and top.
Mounting	Optional rack for mounting several units in a standard rack. Can be combined with 300 watt series units. See <a href="#">"Rack Mounting"</a> on page 24.

**Features and Specifications**  
Chassis Dimensions and Weight

---

Approvals (up to 120 Vdc output)	CSA certified to CSA C22.2 No. 107.1 FCC Part 15B and Industry Canada Class A CE Marked for Low Voltage Directive and EMC Directive (Class A emissions)
----------------------------------	--

---

**Chassis Dimensions and Weight**

**Single Output Unit**

---

Height	5.25 in. (132 mm)
Width	4.25 in. (109 mm)
Depth	11.7 in. (297 mm)
Weight	7.7 lb. (3.5 kg)

---

**Dual Output Unit**

---

Height	5.25 in. (132 mm)
Width	8.5 in. (216 mm)
Depth	11.7 in. (297 mm)
Weight	14.2 lb. (6.5 kg)

---

**Triple Output Unit**

---

Height	5.25 in. (132 mm)
Width	12.75 in. (325 mm)
Depth	11.7 in. (297 mm)
Weight	26.3 lb. (6.5 kg)

---

**Quad Output Unit**

---

Height	5.25 in. (132 mm)
Width	17.0 in. (436 mm)
Depth	11.7 in. (297 mm)
Weight	36.7 lb. (16.7 kg)

---

**Features and Specifications**  
Chassis Dimensions and Weight

# Section 2. Installation

## Introduction

This section provides recommendations and procedures for inspecting, installing, and testing the power supply.

## Basic Setup Procedure

**Table 2.1** Basic Setup Procedure

Step#	Description	Action	Reference
1	Inspection	Perform an initial physical inspection of the supply.	“Initial Inspection” on page 21
2	Installation	Install the supply and ensure adequate ventilation.	“Location and Ventilation” on page 22
3	Test	Perform functional tests for voltage mode operation, current mode operation, and front panel controls.	“Functional Tests” on page 23

## Initial Inspection

Verify that the power supply was shipped with an IEC power cord set appropriate to the destination country and an operating manual. When you first receive your unit, perform a quick physical check.

1. Inspect the unit for scratches and cracks, broken switches, connectors, terminals, and missing accessories.
2. Have a service technician check the unit if you suspect internal damage.

If the unit is damaged, save all packing materials and notify the carrier immediately.

### **Periodic Cleaning**

No routine servicing of the power supply is required except for periodic cleaning. Whenever a unit is removed from operation, clean the outside surfaces with a weak solution of soap and water. If required, use low-pressure compressed air to blow dust from in and around components on the printed circuit boards.

## Installation

### Rack Mounting

## Rack Mounting

Use the power supply in benchtop or in rack-mounted applications.



### WARNING

Ensure that any mounting screws do not protrude more than 1/8 in. (3.0 mm) into the bottom of the unit.

---

The power supply is designed to fill 1/4 of a standard 19 in (483 mm) equipment rack.

Dual and quad configurations can be combined with 300 watt series models for custom applications. Contact the manufacturer about the rack mount kit (Option RM).

## Location and Ventilation

Whether you place the power supply in a rack or on a bench, allow cooling air to reach the ventilation inlets on the bottom and sides of the unit. Ensure that rack-mounted supplies have 1 U (1.75 in) above and below units. Any ventilation space around the supply will further lower internal operating temperatures.

See “Environmental Specifications” on page 18, for the operating altitude specification and the operating ambient temperature range measured at the unit case.

## AC Input Power Connection



### WARNING

There is a potential shock hazard if the power supply chassis and cover are not connected to an electrical ground via the safety ground in the AC input connector. Ensure that the power supply is connected to a grounded AC outlet with the recommended AC input connector configured for the available line voltage as described in this section.

---



### CAUTION

When power switch is turned on, output voltage or current previously set will be applied to loads.

---

The AC input connector is a standard IEC 320 male connector located on the power supply's rear panel.



**Table 2.2** Operational AC Input Voltage Ranges and Frequency

AC Voltage Range	Frequency
104-127 Vac 1 $\phi$ (standard)	57-63 Hz
200-250 Vac 1 $\phi$ (AC220 / AC230 / AC240 options) 110 Vac (option M1) 115-230 Vac switching unit (option M43)	47-63 Hz

## AC Input Cord



### WARNING

The AC input cord is the disconnect device for the power supply. The plug must be readily identifiable by and accessible to the operator. The input cord must be no longer than 9.85 feet (3 m).

The AC input cord that we provide is appropriate to the destination country. If you require a special cord, call us.

## Functional Tests

These functional test procedures include power-on and front panel function checks as well as voltage and current mode operation checks.

### Power-on Check

1. Ensure that the front panel power switch is in the extended (OFF) position and the voltage and current controls are in their fully counter-clockwise positions.
2. Ensure that the AC line voltage is within operating range.
3. Plug the line cord into a grounded AC outlet.
4. Push the power switch to turn on the power supply.

After a short power-on delay, the display and the red current mode LED lights. The meter reading remains at zero.

For more about standard operations, see Section 4, “Operation”.

## Installation

### Functional Tests

#### **Voltage Mode Operation Check**

1. Ensure that the front panel voltage and current control are turned fully counter-clockwise.
2. Set the power switch to ON.
3. Rotate the current control one half-turn clockwise. Slowly rotate the voltage control clockwise and observe the digital meter. Minimum control range should be from zero to maximum rated output. Observe the bar graph meter to see that it tracks as the voltage rises. Verify that the voltage mode indicator light is ON.
4. Set the power switch to OFF.

#### **Current Mode Operation Check**

1. Ensure that the front panel power switch is set to OFF.
2. Rotate the voltage and current controls fully counter-clockwise.
3. Rotate the voltage control one half-turn clockwise.
4. Connect a short circuit across the output terminals. Use leads of sufficient current carrying capacity.
5. Set the power switch to ON.
6. Rotate the current control slowly clockwise. The control range should be from zero to the maximum rated output. Also check that the current bar graph meter follows the rise in current and that the current mode indicator light is ON.
7. Set the power switch to OFF.

# Section 3. Load Connection and Sensing

## Introduction

This section covers single and multiple load connection, constant voltage and constant current operating modes, and alternate power supply configurations such as series and parallel connections.

## Load Connection



### WARNING

There is a potential shock hazard at the load when using a power supply with an output greater than 40 V. Take appropriate precautions to protect personnel against accidental contact with hazardous voltages. Also ensure that the insulation rating of the load wiring and circuitry is greater than or equal to the maximum voltages to ground being applied.

---



### CAUTION

When making load connections, be sure to observe correct polarity locations or damage to the power supply may occur.

---

You can obtain reliable performance from your power supply if you take certain basic precautions when making load connections.

To obtain a stable, low noise output, pay attention to factors such as conductor ratings, system grounding techniques, and the way that you make AC input, DC output, and remote sensing connections. Use a conductor size that satisfies the current rating requirements. To overcome impedance and coupling effects, we recommend larger gauge wire and shorter leads.

Where positive load transients such as back EMF (electromotive force) from a motor may occur, connect a transorb or a varistor across the output to protect the power supply.

## Load Connection and Sensing

### Load Connection

**Load Wiring** To select wiring for connecting the load to the power supply, consider the following factors:

- insulation rating of the wire
- current carrying capacity of the wire
- maximum load wiring length for operation with sense lines
- noise and impedance effects of the load lines

**Insulation Rating** Use load wiring with a minimum insulation rating at least equivalent to the maximum output voltage of the power supply. If the output is offset from ground, the insulation must be rated at least for the sum of the supply's maximum output and the offset.

**Current Carrying Capacity** As a minimum, load wiring must have a current capacity greater than the output current rating of the power supply. This ensures that the wiring will not be damaged even if the load is shorted. See Table 3.1 for the maximum current rating, based on  $450 \text{ A/cm}^2$ , for various gauges of wire rated for  $105^\circ\text{C}$  operation. Operating at the maximum current rating results in an approximately  $30^\circ\text{C}$  temperature rise for a wire operating in free air. Where load wiring must operate in areas with elevated ambient temperatures or bundled with other wiring, use larger gauges or wiring rated for higher temperatures.

**Table 3.1** Current Carrying Capacity for Load Wiring

Wire Size (AWG)	Maximum Current (A)	Wire Size (AWG)	Maximum Current (A)
20	2.5	6	61
18	4	4	97
16	6	2	155
14	10	1	192
12	16	1/0	247
10	21	2/0	303
8	36		

**Load Wiring Length for Operation with Sense Lines** For applications using remote sensing, you must limit the voltage drop across each load line. See Figure 3.1 for some maximum allowable lengths for a given load current and wire size. We recommend that you use the larger load wiring to ensure a smaller voltage drop (0.1 V typical maximum), although units can compensate for up to 0.5 V drop in each line<sup>1</sup>.)

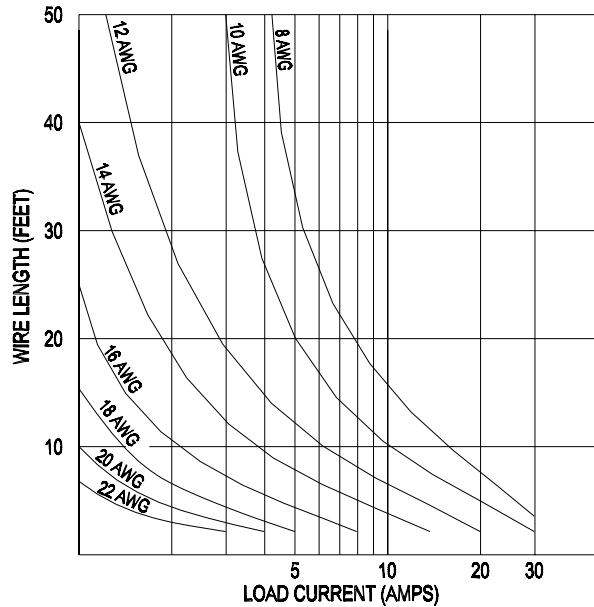

Figure 3.1 Maximum Wire Length for 100 mV Line Drop

**Noise and Impedance Effects** To minimize noise pickup or radiation, use shielded pair wiring of the shortest possible length for load wires. Connect the shield to the chassis via the front panel binding post or a rear panel mounting screw. Where shielding is impossible or impractical, simply twisting the wires together will offer some noise immunity.

**Making Load Connections**

**Front Panel Binding Posts** To make connections at the front panel, connect load wires using stripped wire (0.6"), tongue lugs, or banana plugs to the output binding posts.

For binding posts locations, see Figure 1.1 Front Panel Controls, p. 13.

1. Any losses in the load cables must be deducted from the maximum output voltage of the supply. For example, a 15 V supply with a 1 V loss in the load cables can supply a maximum of 14 V regulated at the load.

## Load Connection and Sensing

### Grounding

**Rear Panel Terminals** To make load connections, attach the wire using the steps below:

1. Strip load wires 0.25 in.(6 mm)
2. Using a flat-bladed 1/8 in. (3 mm) screwdriver, loosen the positive (+) and negative (-) output terminal screws on the output terminal block.
3. Insert the wire into the bottom of the block and tighten screw.

### Connecting Multiple Loads

Proper connection of distributed loads is an important aspect of power supply use. A common mistake is to connect leads from the power supply to one load and then from that load to other loads. In this parallel power distribution method, the voltage at each load depends on the current drawn by the other loads, and DC ground loops develop. Except for low current applications, we recommend that you do not use this method.

It is preferable to distribute power via the radial distribution method — in which power is connected individually to each load. In the radial method, a single pair of terminals are designated as the positive and negative distribution terminals. This pair of terminals may be the power supply output terminals, the load terminals, or a distinct set of terminals specially established for distribution. In this scheme, there are no ground loops and the effect of one load upon another is minimized.

## Grounding

Make proper ground connections to avoid developing paths between separate ground points. To avoid ground loops, there must be only one ground return point in a power system. If the load itself is not grounded, ground the positive or negative output (as appropriate) to the supply's chassis using a rear panel screw or the front panel ground binding post.

## **Local Sensing**

Sensing of the output voltage is available from both the rear panel and the front panel output connectors. Default local sensing regulates the voltage at the power supply output terminal. Use remote sensing (see “Remote Sensing” on page 32) when the voltage needs to be regulated at the load rather than at the power supply output terminals.

Without sense line connections, the supply regulates the voltage at the output terminals of the power supply.

See Figure 1.1 Front Panel Controls, p. 13, and Figure 1.3 Rear Panel., p. 14, for sense terminal locations on the front and rear panels.

## Load Connection and Sensing

### Remote Sensing

## Remote Sensing



#### **WARNING**

There is a potential shock hazard at the sense points when using a power supply with a rated output greater than 40 V. Ensure that connections at the load end are shielded to prevent contact with hazardous voltages.

---



#### **CAUTION**

Operation of the supply in remote sense mode without the assured connection of the load wires and remote sense wires to the load may damage the power supply.

---



#### **CAUTION**

Ground the sense line shield in one place only. Locations include: the power's supply's return output connection at the load, the power supply's return output at the negative output terminal, or the power supply's ground binding post on the front panel.

---

Remote sensing permits you to relocate the regulation point of the power supply from the output terminals to the load or other distribution point terminals.

The power supply provides sense connections beside the output terminals at the front and rear panels. Use 22-24 AWG twisted, shielded pair wiring to make sense connections.

With remote sense leads in place, the supply regulates for the displayed voltage at the point where the sense lines are connected to the output leads (provided the sum of these lead losses does not exceed 0.5 V). With the sense lines disconnected, the supply regulates the voltage at the output terminals.

#### **Note**

Do not operate the supply with sense lines connected to the load without also connecting the normal load power leads to the output terminals.

Avoid reversing positive (+) and negative (-) lead connections.

Always use shielded pair wiring for sense lines to minimize noise effects (see "Grounding" on page 30).

---



# Section 4. Operation

## Introduction

Once you have installed the power supply and have connected both the AC input power and the load as covered in Section 2 Installation, the power supply is ready to operate.

- Operating Modes, below, offers a brief explanation of Constant Voltage and Constant Current Mode operation.
- “Connecting Multiple Supplies in Series (Voltage Mode Only)” on page 35, covers using multiple supplies.

## Operating Modes

Your power supply has two basic operating modes: Constant Voltage Mode and Constant Current Mode. The mode in which the power supply operates at any given time depends on the combination of:

- output voltage setting  $V_{SET}$
- output current limit setting  $I_{SET}$
- resistance or impedance of the attached load  $R_L$

Figure 4.1 represents the relationships between these variables.

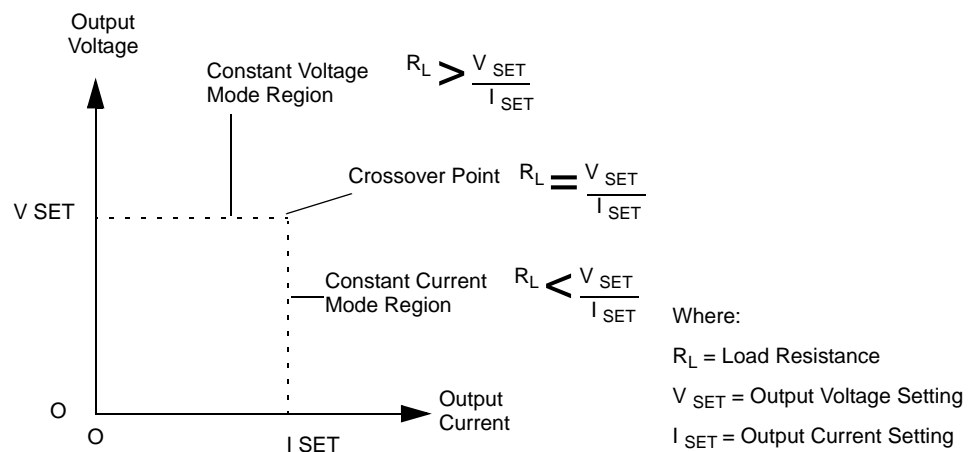

Figure 4.1 Operating Modes

## Operation

### Operating Modes

---

**Note** The control circuits have been designed to allow you to set output voltage and current up to 5% over the model-rated maximum values. The power supply will operate within these extended ranges, but we cannot guarantee full performance to specification.

---

#### **Constant Voltage Mode Operation**

The power supply will operate in constant voltage (CV) mode whenever the load current  $I_L$  is less than the current limit setting  $I_{SET}$  or:  $I_L < I_{SET}$  (Note:  $I_L = V_{SET} / R_L$ ). In CV, the power supply maintains the output voltage at the selected value ( $V_{SET}$ ) while the load current  $I_L$  varies with the load requirements.

To use the power supply in CV mode, either set the current limit to maximum by turning the current control to its extreme clockwise position, or take the precaution of setting a desired maximum current, then set the voltage control to the desired voltage.

#### **Constant Current Mode Operation**

The power supply will operate in constant current (CI) mode whenever the load resistance is low enough that at  $V_{SET}$  the load current would be greater than the current limit setting  $I_{SET}$ .

$$\frac{V_{SET}}{R_L} > I_{SET}$$

In CI mode, the power supply maintains the output current at the selected value ( $I_{SET}$ ) while the output voltage varies with the load requirements.

To set the Current Limit, connect a shorting lead across the output terminals, turn the voltage control a half-turn clockwise, and set the desired maximum value of current limit by turning the current control slowly clockwise to the desired level. Then, disconnect the shorting lead from the output terminals. The power supply will now automatically switch into current limiting mode (current regulation) as soon as the preset current level is reached. To operate the supply in CI mode, set the current limit as described above, then set the voltage control fully clockwise or to the compliance voltage of the circuit. As soon as the supply starts operating in current mode, the red current mode LED will turn on.

**Automatic Mode Crossover** The automatic crossover system allows the power supply to automatically switch operating modes in response to changing load requirements. For example, if the load current attempts to increase above the setting of the current adjust control, the unit will switch automatically from CV to CI mode. If you lower the load requirements, the supply will automatically return to CV mode.

**Constant Power Loads** When powering constant power loads such as switch mode regulators, it is preferable to run in constant voltage mode, with the current limit set to supply ample current. Operating near the CV/CI transition point can cause operation to become unstable.

## Using Multiple Supplies

**Connecting Multiple Supplies in Series (Voltage Mode Only)** You can operate two or more power supplies with outputs connected in series or in parallel to obtain increased load voltage or current. A split supply configuration allows you to obtain two positive outputs or a positive and a negative output.

---

**CAUTION**  
The maximum allowable voltage in series operation is 400 Vdc.

---

Connect power supplies in series to obtain a single output supply with higher output voltage. Connect the negative (–) terminal of one supply to the positive (+) terminal of the next supply. The total voltage available is the sum of the maximum voltages of each supply (add voltmeter readings). The maximum current available to the load is equal to the current of the lowest rated supply in the series. See Figure 4.2 for a representation of series operation.

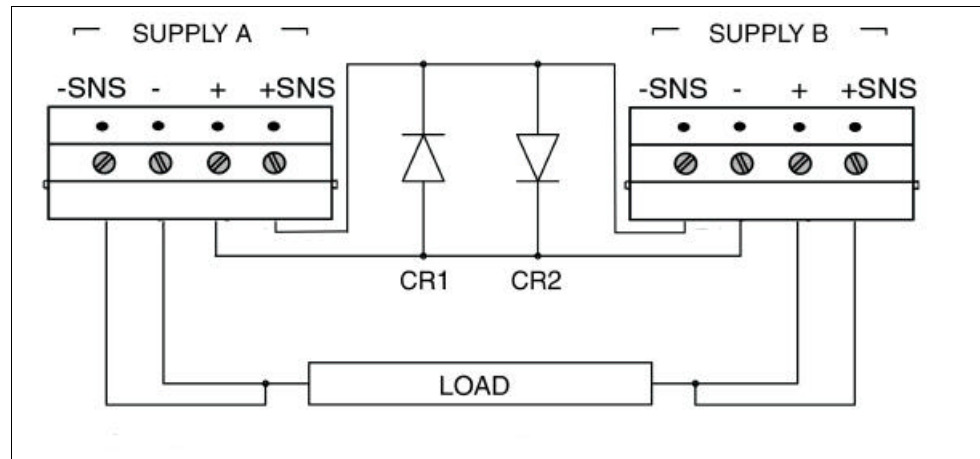

Figure 4.2 Series Operation with and without OVP

## Operation

### Using Multiple Supplies

#### Note

You do not need to use remote sensing for series operation. If you choose to use it, refer to “Remote Sensing” on page 32.

Diodes CR1 and CR2 protect sense circuits during transient events such as momentary current limit events which may cause supply outputs to collapse.

### Connecting Multiple Supplies in Parallel



#### CAUTION

For parallel operation with OVP-equipped supplies, set all OVP trip points higher than the maximum output voltage. To prevent the internal OVP fuse from blowing during OVP trip events, add external blocking diodes as illustrated in Figure 4.3.



#### CAUTION

The configuration shown in Figure 4.3 is for use with local sense only. Do not attempt to use remote sensing with the diodes as shown. Damage to the sense circuits may occur.

Connect power supplies in parallel to obtain a single output supply with a higher output current limit. Set all of the outputs to the same voltage before connecting the positive (+) and negative (–) terminals in parallel. The total current available is the sum of the maximum currents of each supply.

The maximum voltage available at the load is equal to the voltage of the lowest rated supply. When you connect two supplies in parallel, the supply with the higher voltage setting will be in the current limiting mode, while the other supply controls the output voltage.

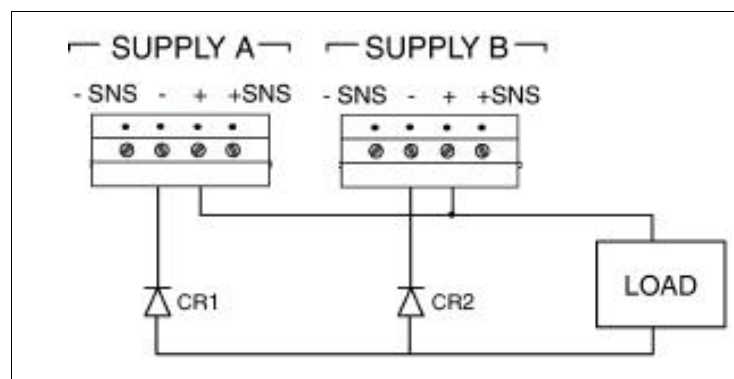

**Figure 4.3** Parallel Operation with OVP-equipped Units  
(Local Sensing Only)

**Split Supply Operation** Split supply operation uses two power supplies to obtain two positive voltages with a common ground, or to obtain a positive-negative supply.

**Two Positive Voltages** To obtain two positive voltages, connect the negative output terminals of both supplies together in a common connection. The positive output terminals will provide the required voltages with respect to the common connection.

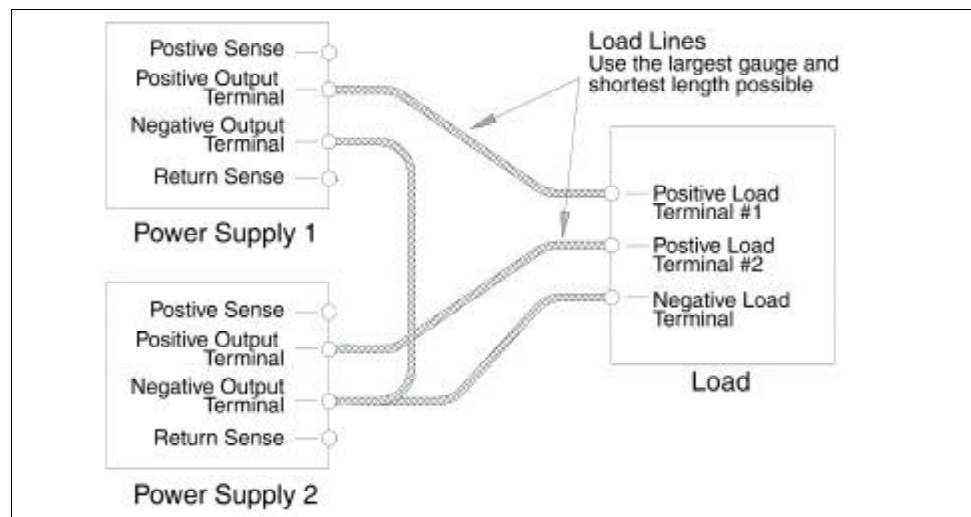
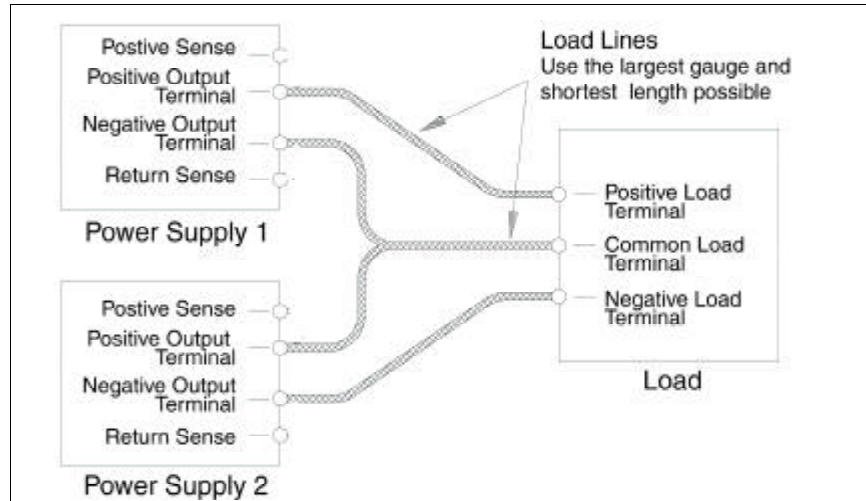

**Figure 4.4** Split Supply Operation of Multiple Supplies (Two positive voltages)

**Positive-negative supply** To obtain a positive-negative supply, connect the negative output terminal of one supply to the positive terminal of the second supply. The positive output terminal of the first supply now provides a positive voltage relative to the common connection. The negative output terminal of the second supply provides the negative voltage. The current limits can be set independently of each other. The maximum current available in split operation is equal to the rated output of the supplies.

## Operation

### Using Multiple Supplies



**Figure 4.5** Split Supply Operation of Multiple Supplies (Positive-negative supply)

---

**Note** The optional Analog Programming (APG) Interface has a Master/Slave Tracking feature which will allow one-knob control of both supplies in a split supply configuration.

---